

Specifications

- Double sided acrylic based adhesive tape
- Designed for bonding high and medium energy substrates
- Absorbs thermal expansion of varying materials
- Maintains high impact resistance even at temperatures below 0° Celsius
- Very high initial tack with very good plasticizer resistance
- Thin or textured surfaces can be bonded full surface and tension free

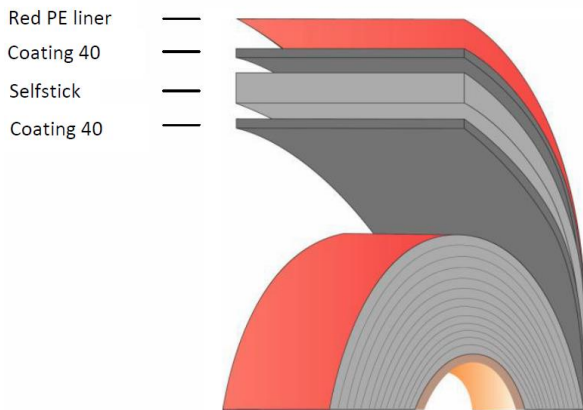

Thickness:	1,2 mm (0.047 inch) ± 10%
Core:	Conformable acrylic
Adhesive:	Acrylic coating 40
Density:	840 kg/m ³ (52lb/ft ³)
Color:	Light Gray
Liner:	Red PE liner
Solvent Resistance:	Excellent
UV Resistance:	Excellent
Temperature Resistance:	
Minimum	-40°C (-40°F)
Short term	160°C (320°F)
Long term	100°C (212°F)

90° Peel Adhesion	N/10mm (lb/in)	41 (23)		ASTM D3330
Dynamic Shear Strength	kPa (lb/in ²)	590 (85)		ASTM D-1002
Normal Tensile	kPa (lb/in ²)	590 (85)		ASTM D-897
Static Shear Strength	Grams Weight that ½ square inch will hold for 10,000 minutes (7 days)	22°C (72°F)	1000	ASTM 3654
		66°C (150°F)	500	
		93°C (200°F)	500	
		121°C (250°F)		
		177°C (350°F)		

Suitable for:

- various high and medium surface energy plastics, glass, steel, aluminum, ceramics*

PLEASE NOTE THAT ALL DATA SHEETS ARE SUPPLIED BY LAMATEK, INC. WITH THE UNDERSTANDING THAT THE PURCHASER MUST DETERMINE THE SUITABILITY OF A PARTICULAR PRODUCT FOR ITS INTENDED PURPOSE. UNLESS OTHERWISE STATED, LAMATEK, INC. CANNOT WARRANT PRODUCTS IN THEIR APPLICATION.

Specifications

- Double sided acrylic based adhesive tape
- Designed for bonding high and medium energy substrates
- Absorbs thermal expansion of varying materials
- Maintains high impact resistance even at temperatures below 0 ° Celsius
- Very high initial tack with very good plasticizer resistance
- Thin or textured surfaces can be bonded full surface and tension free

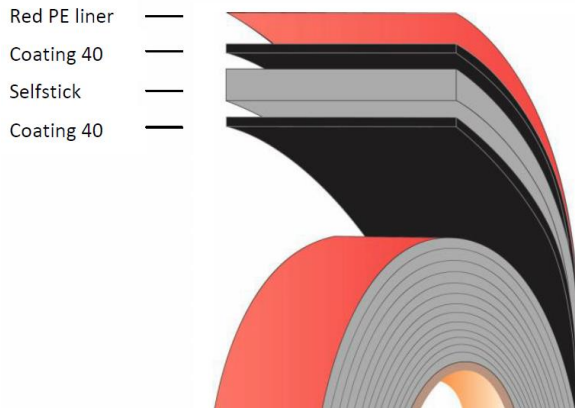

Thickness:	1,2 mm (0.047 inch) ± 10%
Core:	Conformable acrylic
Adhesive:	Acrylic coating 40
Density:	840kg/m ³ (52lb/ft ³)
Color:	Black
Liner:	Red PE liner
Solvent Resistance:	Excellent
UV Resistance:	Excellent
Temperature Resistance:	
Minimum	-40°C (-40°F)
Short term	160°C (320°F)
Long term	100°C (212°F)

90° Peel Adhesion	N/10mm (lb/in)	41 (23)	ASTM D3330
Dynamic Shear Strength	kPa (lb/in ²)	590 (85)	ASTM D-1002
Normal Tensile	kPa (lb/in ²)	590 (85)	ASTM D-897
Static Shear Strength	Grams Weight that ½ square inch will hold 10,000 minutes (7 days)	22°C (72°F) 1000 66°C (150°F) 500 93°C (200°F) 500 121°C (250°F) 177°C (350°F)	ASTM 3654

Suitable for:

- various high and medium surface energy plastics, glass, steel, aluminum, ceramics*

PLEASE NOTE THAT ALL DATA SHEETS ARE SUPPLIED BY LAMATEK, INC. WITH THE UNDERSTANDING THAT THE PURCHASER MUST DETERMINE THE SUITABILITY OF A PARTICULAR PRODUCT FOR ITS INTENDED PURPOSE. UNLESS OTHERWISE STATED, LAMATEK, INC. CANNOT WARRANT PRODUCTS IN THEIR APPLICATION.

Specifications

- Double sided acrylic based adhesive tape
- Designed for bonding high and medium energy substrates
- Absorbs thermal expansion of varying materials
- Maintains high impact resistance even at temperatures below 0° Celsius
- Very high initial tack with very good plasticizer resistance
- Thin or textured surfaces can be bonded full surface and tension free

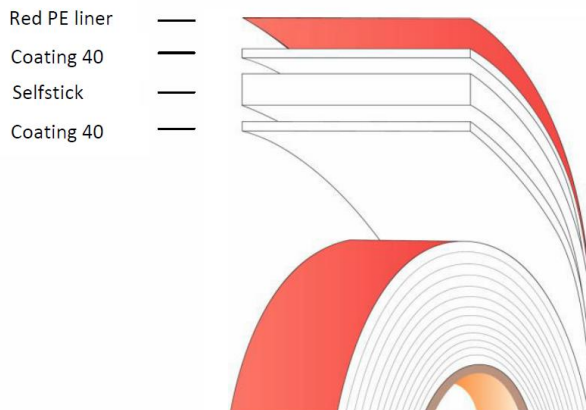

Thickness:	1,2mm (0.047inch) ± 10%
Core:	Conformable acrylic
Adhesive:	Acrylic coating 40
Density:	840kg/m ³ (52lb/ft ³)
Color:	White
Liner:	Red PE liner
Solvent Resistance:	Excellent
UV Resistance:	Excellent
Temperature Resistance:	
Minimum	-40°C (-40°F)
Short term	160°C (320°F)
Long term	100°C (212°F)

90° Peel Adhesion	N/10mm (lb/in)	41 (23)	ASTM D3330
Dynamic Shear Strength	kPa (lb/in ²)	590 (85)	ASTM D-1002
Normal Tensile	kPa (lb/in ²)	590 (85)	ASTM D-897
Static Shear Strength	Grams Weight that ½ square inch will hold 10,000 minutes (7 days)	22°C (72°F) 1500 66°C (150°F) 500 93°C (200°F) 500 121°C (250°F) 177°C (350°F)	ASTM 3654

Suitable for:

- various high and medium surface energy plastics, glass, steel, aluminum, ceramics*

PLEASE NOTE THAT ALL DATA SHEETS ARE SUPPLIED BY LAMATEK, INC. WITH THE UNDERSTANDING THAT THE PURCHASER MUST DETERMINE THE SUITABILITY OF A PARTICULAR PRODUCT FOR ITS INTENDED PURPOSE. UNLESS OTHERWISE STATED, LAMATEK, INC. CANNOT WARRANT PRODUCTS IN THEIR APPLICATION.

Technical Data Sheet | High Bond Acrylic Foam Tape | 45 mil

Manual Production

Every good bond starts with good preparation. This preparation consists of several steps, such as cleaning, use of a primer and the right working area. Please ensure that your workshop area is in a dust free environment and has a minimum room temperature of 59 F° (15 °Celsius).

Cleaning

Before you begin, always check that the materials you want to bond to are clean and dry. If they are highly contaminated with oil or grease, clean them with an industrial cleaner or a heptanes solution. Even when the surface is clean, use a 100% Isopropanol solution cleaner. Ensure that you wipe the surface in just one direction, so that the dirt is wiped off. If you do not do this, you will always leave some dust or dirt on the substrate.

Quality

The quality of the bond also depends largely on the contact that the two surfaces make with each other. Due to its viscoelasticity, the tape is able to flow into the microscopic pores of the materials. However, if there is a big surface mismatch or if the materials are not pressed together the bond will reach its end strength more slowly, or not at all. Therefore, we advise you to put pressure on the bond of at least 15psi to allow the tape to make the strongest bond between the two materials.

Maximum Bond

The end strength will be reached much faster if you use a primer. This enables the tape to reach its end bond within 5 – 20 minutes instead of taking 72 hours. If you have any questions regarding the primer, the manual or the mechanical application, please contact our technical sales team.

Storage & Shelf life

Please make sure that the tape is stored in its original packaging, in a dry place and at a temperature of preferably between 39 F° and 100 F° (4 °C and 38 °Celsius). When the tape is stored under the right conditions, it has a shelf life of 18 months.

Important Information

All technical data in this product data sheet is based on our own experience and independent test labs. These values are representative and cannot automatically be used for your own specific application. You will need to test whether the tape is suitable for your application or project first. We must point out that you need to follow the rules and regulations that are applicable in the state, county or country that you are using our product in. If you have any questions regarding the use of our acrylic foam tape, please contact our technical service or technical sales team. For questions on the warranty, we refer to our delivery terms and conditions, or another warranty document should be agreed on in writing between us and the customer.